

# Gilian<sup>®</sup>

## ***CYCLONE & CASSETTE HOLDER ASSEMBLY KIT***

***Document No. F-PRO-1247***

***(Revision F)***

***SENSIDYNE<sup>®</sup>***

Sensidyne, LP • 1000 112th Circle N, Suite 100  
St. Petersburg, Florida 33716 USA

(800) 451-9444 • (727) 530-3602 • Fax: (727) 539-0550  
web: [www.sensidyne.com](http://www.sensidyne.com) • e-mail: [info@sensidyne.com](mailto:info@sensidyne.com)

### Introduction

The Gilian Cyclone & Cassette Holder Assembly Kit (PN 800061) provides a simple method for centrifugal separation of respirable dust from particulate matter. The assembly is designed to be worn on a shirt collar to obtain a respirable dust sample from the breathing zone.

The assembly consists of a spring-loaded Cassette Holder Assembly and a Cyclone Assembly that interfaces with the inlet of a filter cassette. The cyclone and holding assembly will accept most brands of filter cassettes. The air sampling tubing can be connected either directly to the filter cassette boss, or indirectly with the use of a Leur Taper Adapter.

### Theory of Operation

The concept of the cyclone is to separate respirable dust from particulate matter of 10 microns or more. With an air sampler set at 1.7 LPM, the cyclone inlet draws in the air and creates a spiral action which separates the larger particles from the lighter ones. The cyclone's grit pot accepts the heavier particles while the lighter particles (less than 10 microns) are drawn up and trapped into the filter cassette.

Some filter cassettes provide a built-in hose boss which allows you to connect the tubing directly to the filter cassette (see Figure 1).

#### NOTE

*The Grit Pot [11] and Vortex Finder Assembly [7] must be properly attached before installing the filter cassette.*

### Installation (Direct Connection)

- 1) Spread the Upper [4] and Lower [9] Holding Plates of the Holder Assembly and seat the cassette onto the Vortex Finder Assembly [7] with the cassette inlet boss facing down. The outlet boss is positioned to come through the Upper Holding Plate [4].
- 2) Allow the Holding Assembly to close and secure the cassette into position. Attach the Hosing Assembly [2] to the cassette's outlet boss.

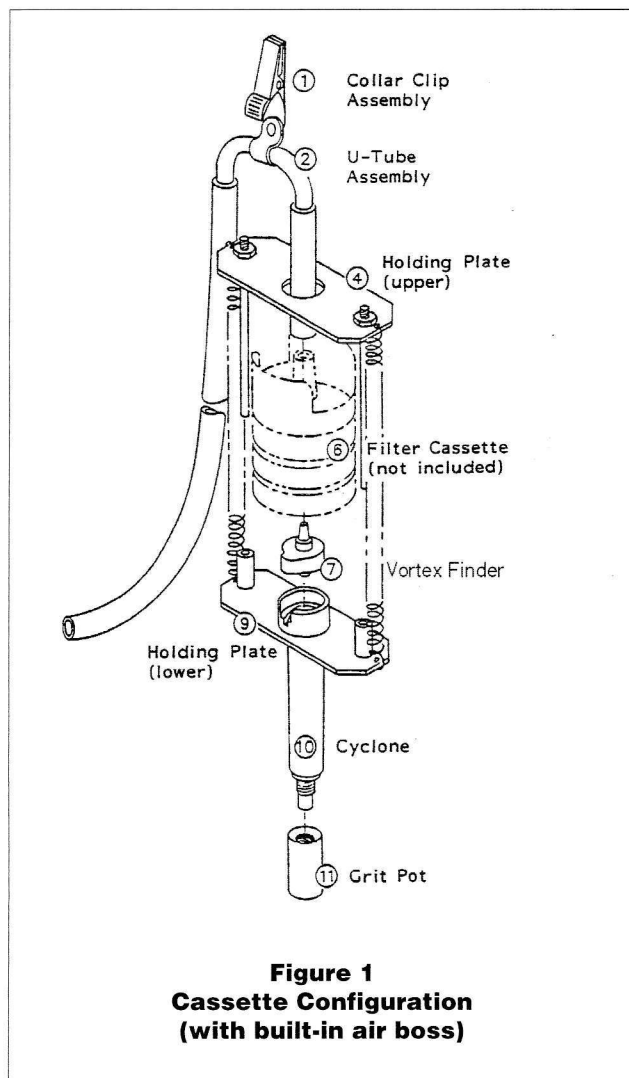

**Figure 1**  
**Cassette Configuration**  
**(with built-in air boss)**

**Installation (Leur Taper Adapter)**

Refer to Figure 2 for installation.

**NOTE**

*The Grit Pot [11] and Vortex Finder Assembly [7] must be properly attached before installing the filter cassette.*

If you are using a cassette without a built-in air boss, you must first install a Leur Taper Adapter [5].

- 1) Seat the Adapter Fitting [19] into the hole located in the Upper Holding Plate [4]. Screw the Locknut [18] to the bottom side of the Adapter Fitting and tighten. The Leur Taper Adapter [5] fits into the cassette's outlet boss.
- 2) With the Leur Taper Adapter in place, spread the Upper and Lower Holding Plates [4 & 9] apart and seat the loaded cassette onto the cyclone's Vortex Finder Assembly [7], with the cassette's inlet boss facing down. Allow the holding plates to close and secure the filter cassette in place.

**NOTE**

*The Leur Taper Adapter will pivot within the adapter fitting. This provides flexibility of movement for the tubing.*

- 3) Attach the Tubing Assembly [2] to the installed Leur Taper Adapter.

The cassette is now properly positioned in the cyclone assembly and can now be connected to the air sampling unit's suction inlet.

**Component Checklist**

Part No.	Description
801608	Cyclone & Holder Assembly
400997-2	Vortex Finder Assembly
200159	Grit Pot
200156	Leur Taper
200330	Adapter Fitting
200331	Locknut
200484	Tubing (36")
801619	Collar Clip & U-Tube Assembly

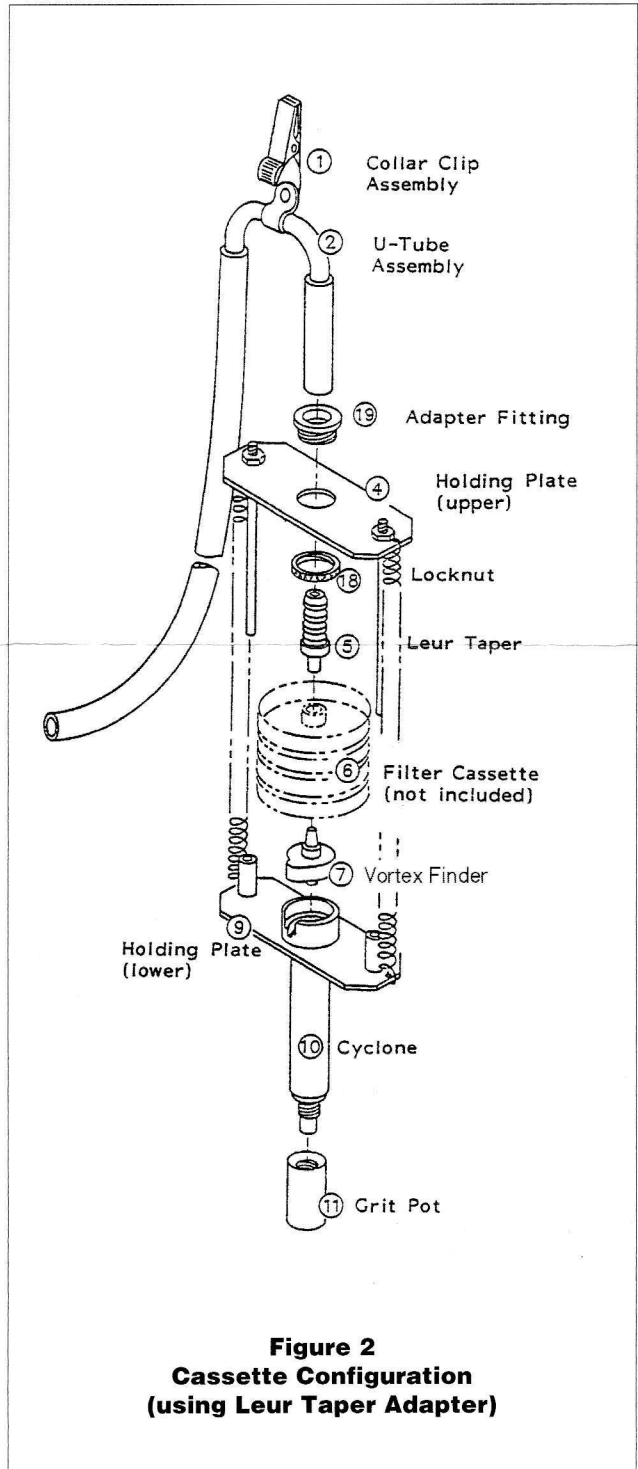

**Figure 2**  
**Cassette Configuration**  
**(using Leur Taper Adapter)**

### Maintenance

Cleaning and leak testing of the Cyclone sampler should be done on a regular basis to maintain performance. The cyclone should be cleaned and checked for cracked or worn parts on a daily basis, and leak tested on a monthly basis.

### Cleaning

Unscrew the grit pot from the cyclone (see Figure 1). Empty the grit pot by turning it upside down and tapping it gently on a solid surface.

The cyclone parts should be cleaned in warm soapy water. *All parts should be left to dry before re-assembly.*

---

### CAUTION

**NEVER insert anything into the cyclone that could scratch the inside surfaces.**

---

### Inspection

The vortex finder, cyclone body, grit pot and grit pot O-ring (see Figure 1) should be inspected for wear, cracks or damage. Replace any worn or damaged parts, as they can impair the performance of the cyclone.

### Leak Testing

Leak testing can be performed in two different ways. The first test is a simple field test that checks for major leaks in the entire assembly.

### Field Test

Attach the Cyclone sampler with filter installed to a charged GilAir-3, GilAir-5, HFS-513 or Gilian 3500 pump (or other constant flow pump). Run the pump at 1.7 LPM ( $\pm 5\%$ ). Block the cyclone inlet with your finger or thumb. The pump should speed up and go into its fault mode, causing the fault indicator to light up.

### NOTE

*This test can also be run using a non constant flow pump (e.g. BDX II). This can be done by observing the pump stall and watching the rotameter ball drop to the bottom of the shaft. However, due to the tight flow control required for cyclone sampling, it is recommended that samples be collected using a constant flow control pump.*

### Bench Test

A more thorough Bench Test checks the individual parts of the system and can be performed using a manometer, an aspirator bulb, and tubing.

Refer to the Occupational Safety and Health Administration's (OSHA) Cyclone Leak Test Procedure for complete instructions. The procedure is also accessible through OSHA's web site at [www.osha.gov](http://www.osha.gov).